

**NEWMEN**

# **NEWMEN crank Forge**

## **Technical Manual**

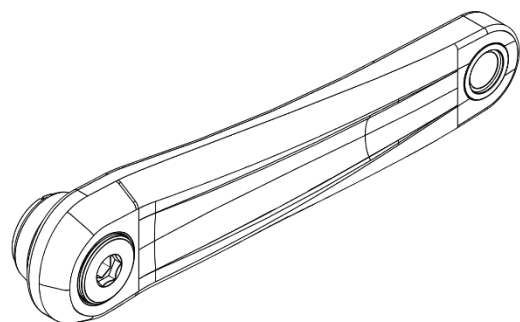
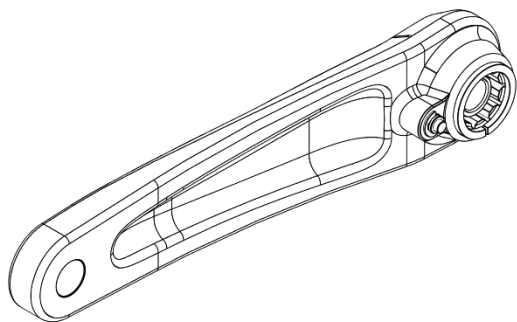

Version: 1.0; Date: 10.09.2024

## Content

1	Safety and instructions for use.....	3
	DANGER.....	3
2	Warranty and crash replacement.....	4
2.1	Warranty summary.....	4
2.2	Crash Replacement summary.....	4
3	Technical data.....	5
3.1	List of tools.....	5
3.2	PIN-IT system.....	6
3.3	Lubricate.....	7
3.4	Crank compatibility.....	8
3.5	Excluded from crank compatibility.....	8
4	Assembly and Maintenance.....	9
4.1	Disassemble.....	9

# 1 Safety and instructions for use



## **DANGER**

Not following the below points can cause the components to fail which can cause the rider to lose control resulting in SEVERE INJURY OR DEATH.

Before and after every ride, check to see whether any of the components are damaged and that everything is still intact. If problems arise, the components should no longer be used. If you are in doubt, please see your local bicycle dealer.

- Follow the manufacturer's instructions for installing the components on the bicycle. The user manuals for all NEWMEN products can be found at [www.newmen-components.de/Downloads](http://www.newmen-components.de/Downloads)
- Follow the manufacturer's safety instructions
- Follow the maximum system weight as specified in the manufacturer's instructions
- Before every ride you should make sure that all the components are properly tightened.
- The components must be compatible with all parts of the bicycle. If in doubt consult your dealer
- The components are only to be used according to their stated purpose. See the document "classification and intended use" at [www.newmen-components.de/Downloads](http://www.newmen-components.de/Downloads) • Only use original replacement parts. Do not change or modify the components.
- All components must be serviced by a specialist dealer according to the maintenance plan in the product manual.
- Do not clean the components with high-pressure power washers.
- If there is any damage or indication of damages, then the components cannot be used without further analysis. If there is any doubt, please contact your local dealer.

MG-Components GmbH & Co KG offer first class service and crash replacement exceeding the legally required warranty. For detailed information please visit [www.newmen-components.de](http://www.newmen-components.de)

## 2 Warranty and crash replacement

In addition to high-quality products, we also offer first-class service. That is why MG-Components GmbH & Co. KG provides not only the legally required warranty on all NEWMEN products, but also an additional three-year warranty on all material and manufacturing defects.

### 2.1 Warranty summary

- All components must be installed and used according to the assembly instructions.
- The respective manufacturer's warranty applies to all third-party parts.
- Improper use, not following the instructions for use, incorrect repair, assembly or maintenance, as well as damages caused by incorrect wheel assembly (spoke pattern, spoke cross, spoke tension, incorrect torque, incorrect lubrication, etc.) are not covered under the warranty.

### 2.2 Crash Replacement summary

- The offer is valid for three years from the date of purchase.
- It can also be transferred to the next owner.
- Damages must affect functionality (visual damages are excluded).
- Replacement is made with the same model. However, MG-Components GmbH & Co. KG reserves the right to replace the damaged article with an alternative product of the same value.
- You have no legal claim to the damaged product, which will become the property of MG-Components GmbH & Co. KG.
- MG-Components GmbH & Co. KG will not pay for costs related to assembly, shipping or customs.
- Crash Replacement is not a substitute for any warranty stipulations that apply in the individual countries.
- Components such as tyres, cassettes, brake discs, brake callipers, etc. must be removed.
- The following is a list of reasons why the Warranty and the Crash Replacement Service guarantee benefits may not apply.
- Damages caused by incorrect installation of the components.
- Damages caused by incorrect repairs to the components.
- Improper use, e.g. a cross-country wheelset used for downhill riding
- Modification to the components
- Maintenance or repairs that were either incorrectly done or not carried out
- Normal wear and tear from use of the components
- Transport and delivery damages
- Improper use and/or mishandling
- Damages from an accident

### 3 Technical data

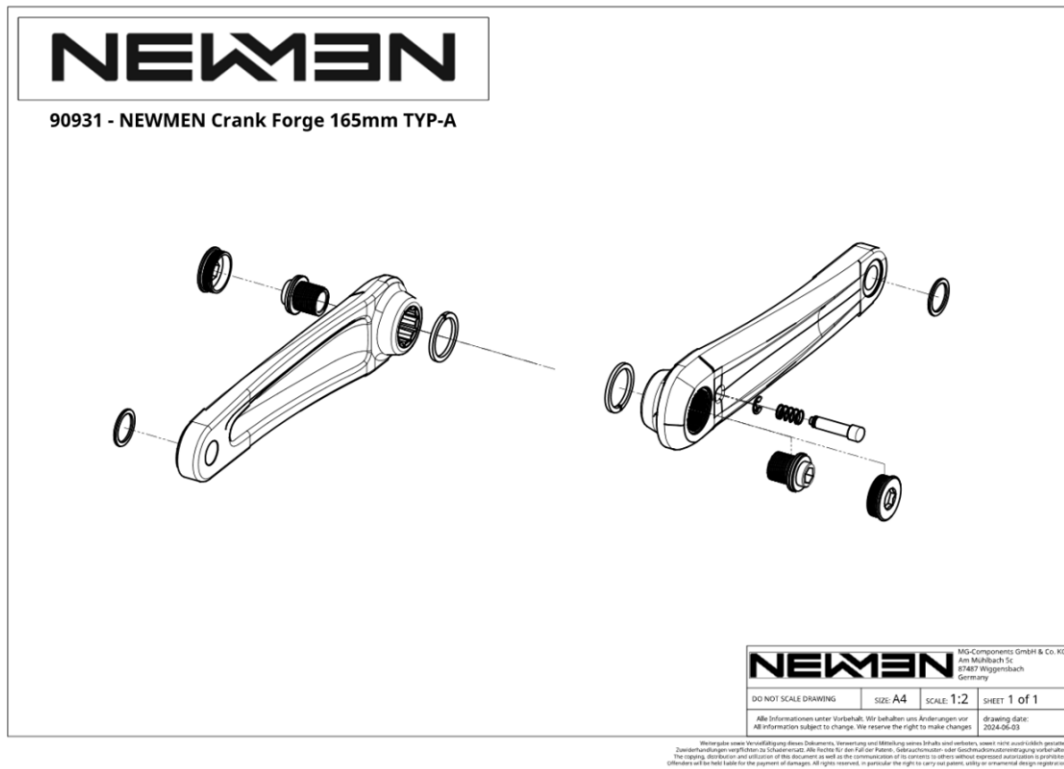

#### 3.1 List of tools

Component	Location used	Tool
Crank arm	Crank bolts	10mm & 8mm hex key + torque wrench
	Self-extraction cap	10mm & 8mm hex key + torque wrench
	Crank arm	grease

### 3.2 PIN-IT system

The NEWMEN crank with the PIN-IT system includes a locking device for the drive unit of an e-bike mid-motor and a freewheel on the rear hub. The pin is installed on the drive side and is held in the zero position by a spring. A retaining ring holds the spring-pin unit in position in the crank. When the pin is pressed, it engages in the groove ring that holds the chainring and can run the entire drive unit backwards with manual force. This allows the chain and the entire drive unit to be lubricated. Once the lubrication process is complete, the pin returns to the zero position when you let go of the crank.



### 3.3 Lubricate

Lubricating the drive unit is very easy with the PIN-IT system. All you must do is press the PIN and lock in the cutout of the lock ring.

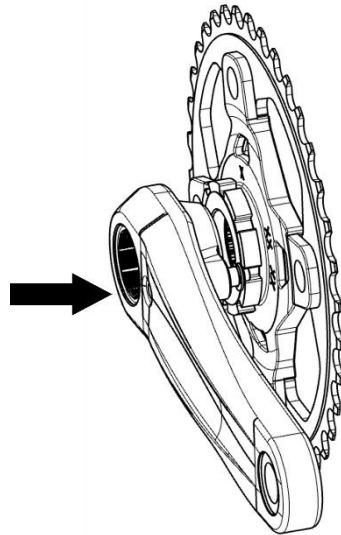

After the Pin is locked the drive unit can then be turned backwards and lubricated.

After coming to a standstill and briefly releasing the load, the pin can spring out of the teeth of the lock ring again.

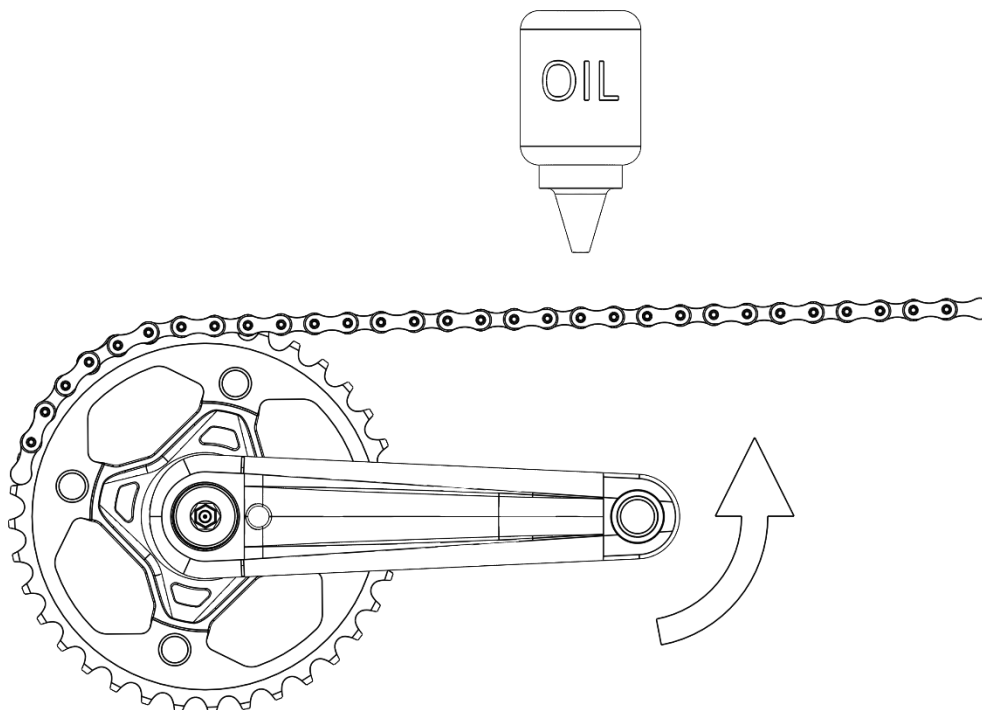

You are ready to ride with a fresh lubricated drivetrain.

### 3.4 Crank compatibility

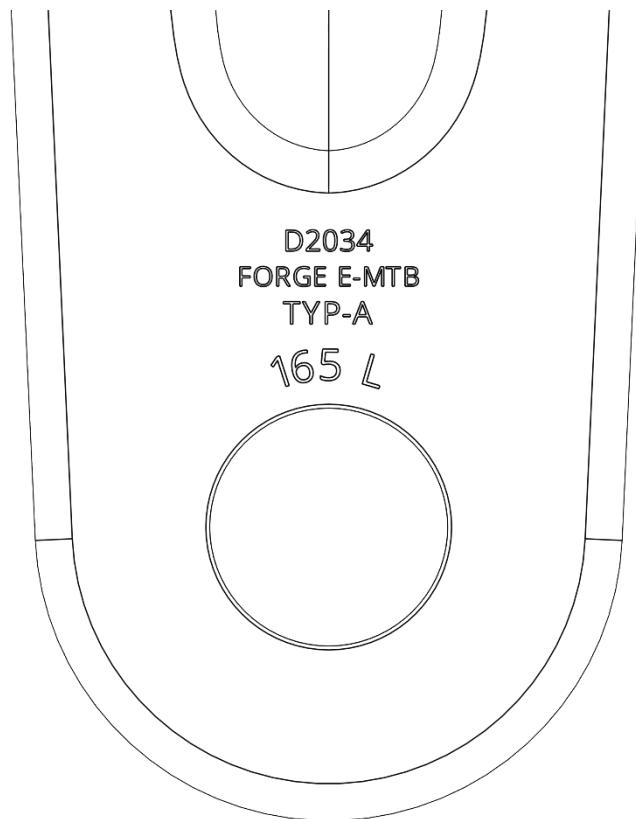

The compatibility of the crank is defined by the marking on the inside of the crank. The third line defines the compatibility of the crank with the drive unit.

For the exact definition go to <https://www.newmen-components.de/Downloads>.

### 3.5 Excluded from crank compatibility

As the PIN-IT system with the PIN on the drive side fills a larger installation space, chainrings with a cover cannot be combined with the NEWMEN crank.

For example, the E\*THIRTEEN MTB chainring E\*SPEC

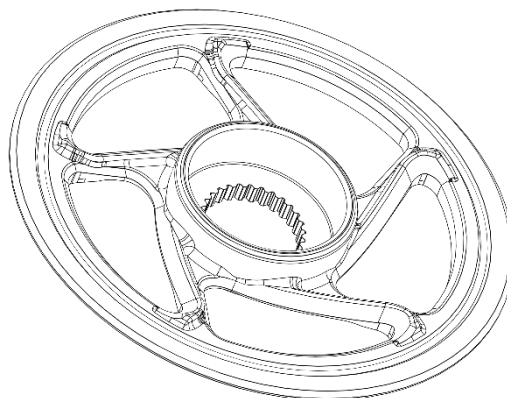



## 4 Assembly and Maintenance

1. Check the compatibility of cranks with drive unit compatibility table. The interface type is shown on the inside of the crank (see photo under 3.4)
2. Check whether the crank is suitable for your bike. The crank must not touch the chainstay or the down tube.
3. Before installing the crank, clean the drive unit and crank interface. Lightly grease the drive unit and crank interface afterwards. Do not grease the thread inside of the drive unit shaft!
4. Tighten the Cap of both cranks with a 10 mm hex key and a torque wrench with 30Nm adjusted. Check whether the self extraction bolt underneath can still move freely.
5. Assemble the washer with slot on both sides of the drive unit shaft.
6. Press the crank by hand on the drive side of the shaft. Tighten the self extraction bolt carefully with an 8 mm hex key to fit the thread correctly. Afterwards use a torque wrench and tighten the crank with 45Nm. Check to have no gap between the crank and the washer and no play between all parts.
7. Make sure the crank arm can rotate without any contact between Press Pin and Bosch lockring.
8. Press the crank onto the brake side of the shaft by hand with a 180° offset to the crank on the drive side. Tighten the inner bolts with an 8 mm hex key to fit the thread correctly. Afterwards use a torque wrench and tighten the crank with 45Nm. Make sure there is no gap between the crank and the washer and no play between all parts.
9. Remove all excess grease.
10. Use the integrated pedal washer from the NEWMEN crank and assemble your pedal with the pedal user manual.

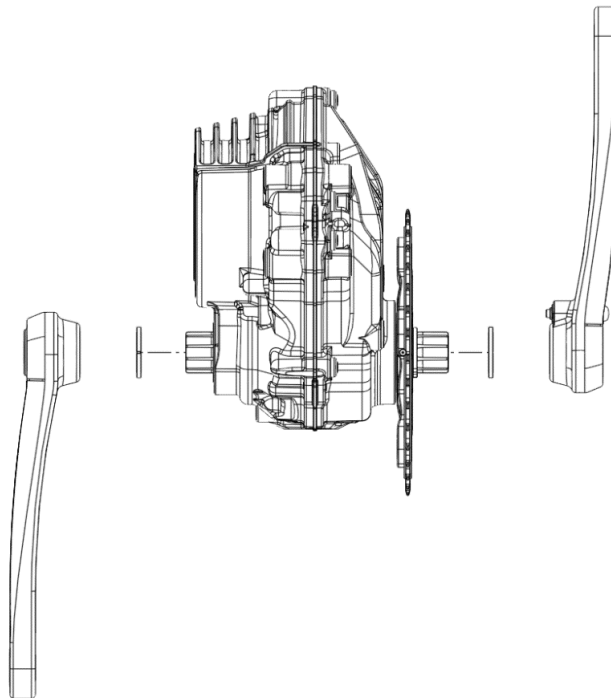

### 4.1 Disassemble

For disassemble the procedure is for both sides the same.

Use a 8mm hex key and turn the self extraction bolt anti-clockwise to release the crank of the shaft.